

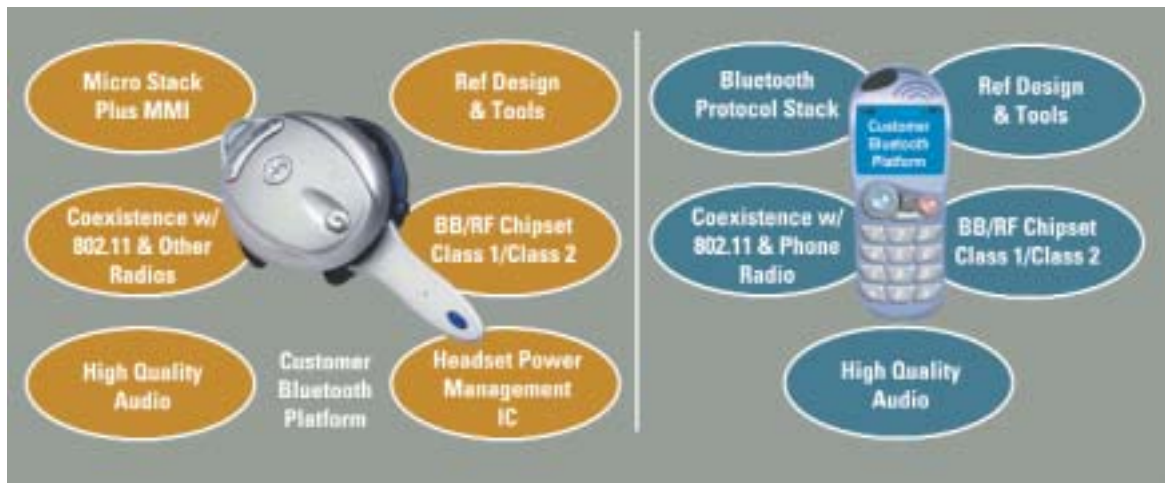

*THE BLUETOOTH™ PLATFORM SOLUTION  
FROM MOTOROLA*

**THE BLUETOOTH PLATFORM SOLUTION  
FROM MOTOROLA**



*Experience the power of an advanced chipset, embedded software, superior radio, high quality audio, 802.11b coexistence, and certified interoperability. The Bluetooth Platform Solution from Motorola makes it easy to get to market fast with your Bluetooth-enabled products.*

With more than 70 years of wireless experience, Motorola is uniquely positioned as a Bluetooth pioneer. As one of only 9 Bluetooth SIG Promoters, we're in an elite group of companies committed to clarifying and improving Bluetooth standards. We were the first to ship Bluetooth products—products that are now regulatory-certified in over 26 countries worldwide. Now, we've leveraged our Bluetooth know-how into a comprehensive, system solution for developing the Bluetooth products of tomorrow: The Bluetooth Platform Solution from Motorola—a complete silicon solution, embedded software, reference designs, and development kits. The Bluetooth Platform Solution from Motorola is flexible, and it gives you a wealth of options for quickly implementing robust, fully tested Bluetooth products. This V1.1 compliant platform is designed to:

- Give your products leading-edge radio performance—along with special 802.11b coexistence capabilities.
- Provide industry-leading noise performance with Motorola patent pending technology—with superior rejection of interference with ISM-band devices such as cordless phones and microwave ovens.

- Assure outstanding audio quality with a special Bluetooth Audio Signal Processor (BTASP).
- Lower overall production costs—with an optimized dual-IC architecture for baseband and RF transceiver functions.
- Facilitate the interoperability that is crucial in a Bluetooth environment—through testing of all components, participation in all Bluetooth UnPlugFests, and a leadership role in the Bluetooth SIG.

All designed with one goal in mind—to assure your success in the market for Bluetooth wireless products. When you select the Bluetooth Platform Solution from Motorola, you'll gain the full benefit of our decades of experience. You'll also gain a partner you can trust.

*A HIGHLY INTEGRATED CHIPSET:  
THE POWER BEHIND YOUR WIRELESS BLUETOOTH PRODUCTS*

Motorola's IC technology has a way of standing out in the industry. Never has this been more true than with Motorola's Bluetooth Platform—a powerhouse chipset that supports a wide variety of customer applications, while assuring superior radio, dedicated audio processor, power conservation, cost effectiveness, and more.

**BLUETOOTH BASEBAND CONTROLLER (MC71000)**

The MC7100 is a Bluetooth V1.1 compliant baseband with standard HCI interface. Its design is based on Motorola's third-generation Bluetooth architecture—an architecture that has set standards for interoperability, complete functionality, and compliance with the Bluetooth spec. Outstanding performance features include a dedicated Bluetooth Audio Signal Processor module—the key to delivering high-quality audio—along with on board ROM to minimize cost.

**WIRELESS DATA TRANSCEIVER (MC13180)**

Combine this low-power transceiver with the baseband controller, and you acquire a comprehensive Bluetooth solution. The MC13180 features a Frac-N synthesizer, JD/MLSE, high/low image reject mixer, complete on-chip VCO, self-adjusting channel filter, and more—designed to maximize coexistence and noise rejection with sources of ISM-band interference. With the data transceiver and the baseband controller on two separate ICs, each can follow its optimal cost-curve—giving you a cost-effective, comprehensive Bluetooth solution. What's more, because the transceiver is implemented in Motorola's unique CDR1 BiCMOS process, it provides outstanding performance while helping keep costs down.

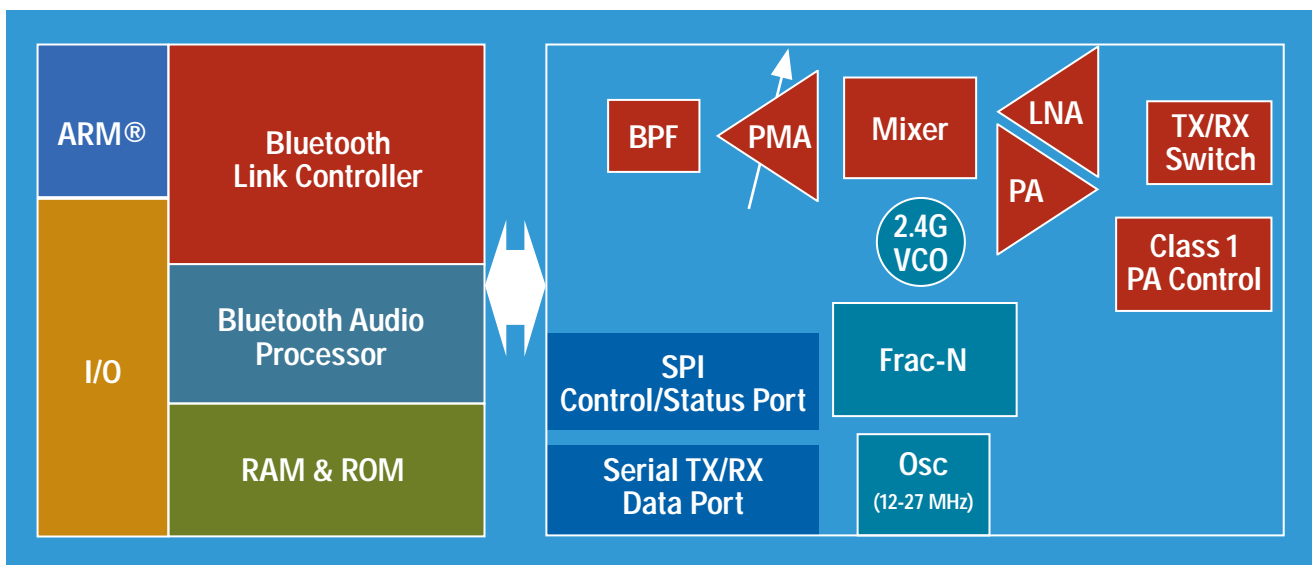

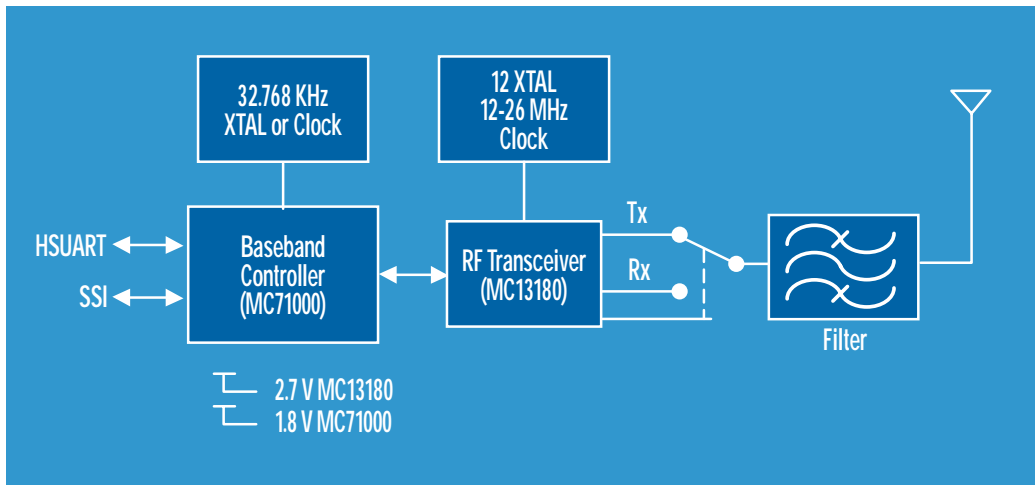

### CLASS 2: A COST-EFFECTIVE BLUETOOTH IMPLEMENTATION

The baseband controller and data [RF] transceiver form the core of all Bluetooth implementations. Here is an example of a cost-effective design. Clocks can come from the host system, or a dedicated crystal can supply them. The platform solution is designed to support the reuse of a wide range of system clocks, up to the latest GPRS 26 MHz frequencies.

### CLASS 1: GREATER RANGE, MORE ROBUST LINK QUALITY

When you add the MRFIC2408 power amplifier to a basic Class 2 implementation, you get a Class 1 product like the one shown here. The power amplifier enables a seamless interface to the wireless data transceiver—using a common power supply, and delivered in a very small package.

**OPTIONAL WIRELESS POWER MANAGEMENT IC (MC13181) FOR HEADSET AND PHONE ACCESSORY PRODUCTS**

In headsets and phone accessory products, the MC13181 Power Management IC joins the baseband controller and wireless data transceiver and integrates discrete functions typical in these applications. It is designed for devices operating from a 3.6 V single-cell battery, or from other energy sources in the 2.5 V to 6.5 V range—making it ideal for cell phones accessories, headsets, and similar products.

**OPTIONAL RF POWER AMPLIFIER FOR BLUETOOTH APPLICATIONS (MRFIC2408)**

This power-packed chip, in one of the smallest packages available, is intended for 2.4 GHz ISM-band applications. It contains power control circuitry and can be used to implement Bluetooth Class I operation. Featuring a low-power shutdown mode and up to 23 dBm of power output, this RF power amplifier is designed to work in a power supply range of 2.7 V to 3.6 V and includes a power amplifier enable/disable function.

**COMPREHENSIVE DEVELOPMENT TOOLS: SO YOU CAN BUILD BLUETOOTH PRODUCTS IN RECORD TIME**

The Bluetooth Platform Solution from Motorola Development Kit is a BQB qualified platform that helps to dramatically speed the time to market for your Bluetooth products. Right out of the box, you can use the development kit to prototype and develop a Class 1 or Class 2 Bluetooth solution—far more quickly and easily than you may have thought possible. Helping you along are complete, real world reference layouts of the baseband controller and the data transceiver on a FR4 PCB substrate. Plus, this convenient turnkey solution contains working hardware, application software, software utilities, and documentation—everything you need to quickly design products for market.

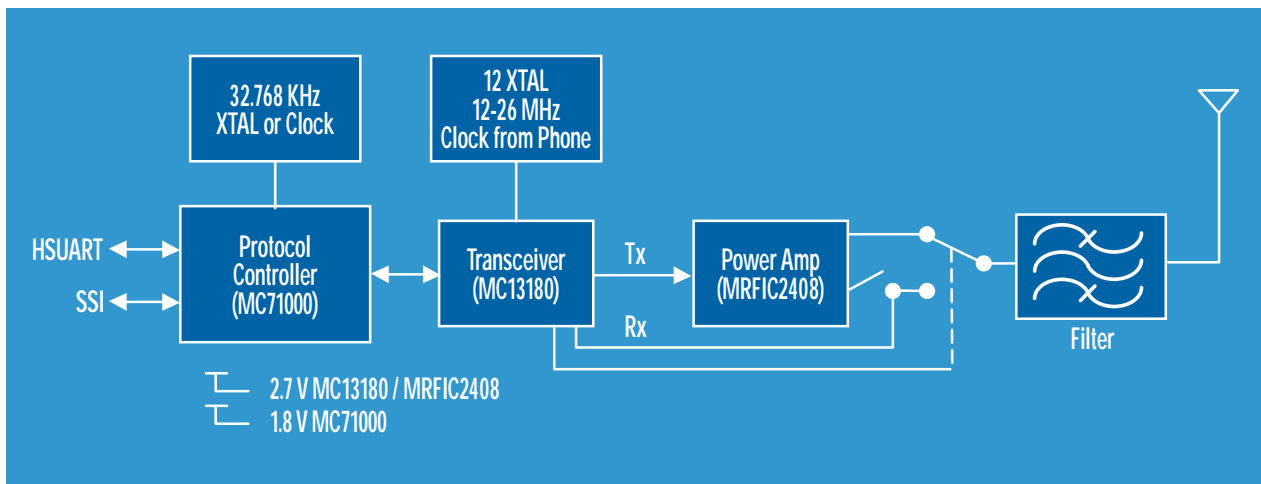

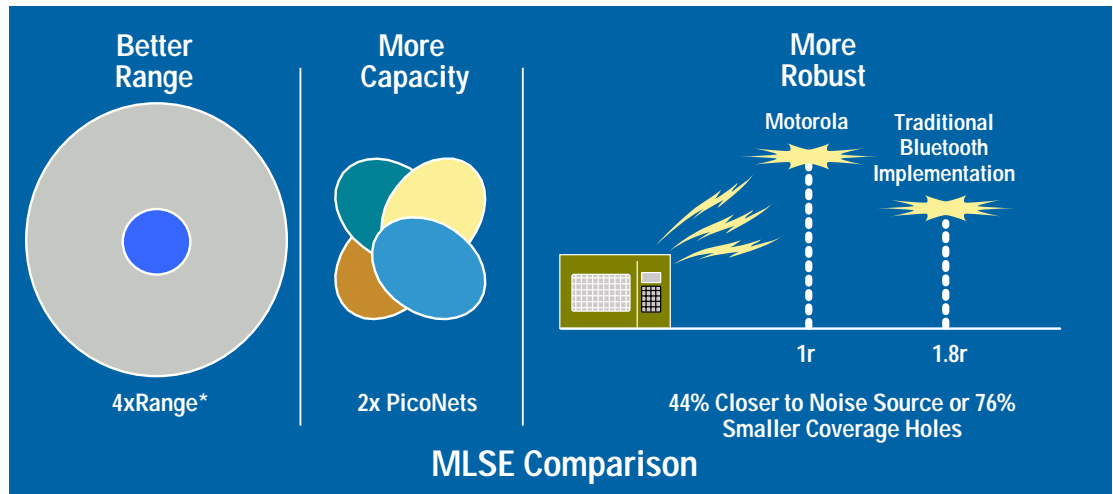

*The Bluetooth Platform Solution from Motorola has four times the range\*, supports twice as many piconets in the same area, superior operation in close proximity to noise sources, as well as coexistence with 802.11b radios.*

**COEXISTENCE WITH 802.11b:**

**KEEPING YOU CONNECTED IN A CROWDED SIGNAL ENVIRONMENT**

Motorola, since the beginning of its Bluetooth development, has been aware of the challenging issues of interference rejection and coexistence with 802.11b. Thus, Motorola put a heavy emphasis on interference rejection performance into its design plan. The Bluetooth Platform Solution from Motorola incorporates:

- A Maximum Likelihood Sequence Estimator (MLSE) rejects possible interference and is designed to give your Bluetooth products the best noise performance in the industry.
- Adaptive Frequency Hopping is designed to combat interference—and to benefit other radios and interference as much as the Bluetooth radio.
- The Joint Detector increases the reliability of the access code detection. This minimizes unnecessary re-transmissions that might interfere with other devices operating in the ISM band, such as 802.11b devices and lowers power consumption.

The results? A much improved Bluetooth user experience. Not only does Motorola's unique MLSE technology enable a robust link around 802.11b WLAN radios—and around other ISM-band devices, such as microwave ovens and cordless phones—but it also provides better range, more capacity, and improved quality versus traditional bit slicing radios\*. The better range not only allows improved service availability, but also increases the service coverage area by up to 16 times\*. The additional capacity means throughput is maintained in high-density Bluetooth environments like airports. The improved quality is provided by Motorola's interference rejection that allows fewer service outages when strong interference like microwave ovens or other radios are nearby.

\*compared to a Bluetooth Specification V1.1 compliant bit slicing radio

*INTEROPERABILITY:  
ASSURING ONE OF YOUR MOST CRITICAL SUCCESS FACTORS*

Interoperability is another major concern of the Bluetooth community—and for good reason. In real-world implementations, a multitude of Bluetooth products, likely from different vendors, will be called upon to interoperate transparently. The sheer complexity of the Bluetooth architecture means a careful, methodical approach is required for such interoperability to be achieved. That is why Motorola has implemented a five pronged interoperability strategy:

- Comprehensive system implementation. Motorola offers a comprehensive platform whose qualified components reduce the chance of interoperability problems due to component mismatch.
- TTCN-based development test framework. We use this formal test scripting language to exercise the solution at the HCI-and-below level. The result? A robust, solid implementation of the Bluetooth protocol.

- SIG standards participation. At Motorola, we know that a clear, precise standard is key to interoperability. So we have expanded our leadership position on the Bluetooth SIG—not only to clarify and evolve Bluetooth features, but also to assure early and frequent testing of reference implementations.
- UnPlugFest participation. At the SIG-sponsored UnPlugFests around the world, we're there—testing platform components for interoperability and making sure the components can be expected to function seamlessly in any environment.
- Informal testing. Finally, we meet regularly with leading Bluetooth developers to clarify implementation questions and verify interoperability.

These efforts have paid off. Quite simply, The Bluetooth Platform Solution from Motorola can be expected to give you the highest level of interoperability available—anywhere.



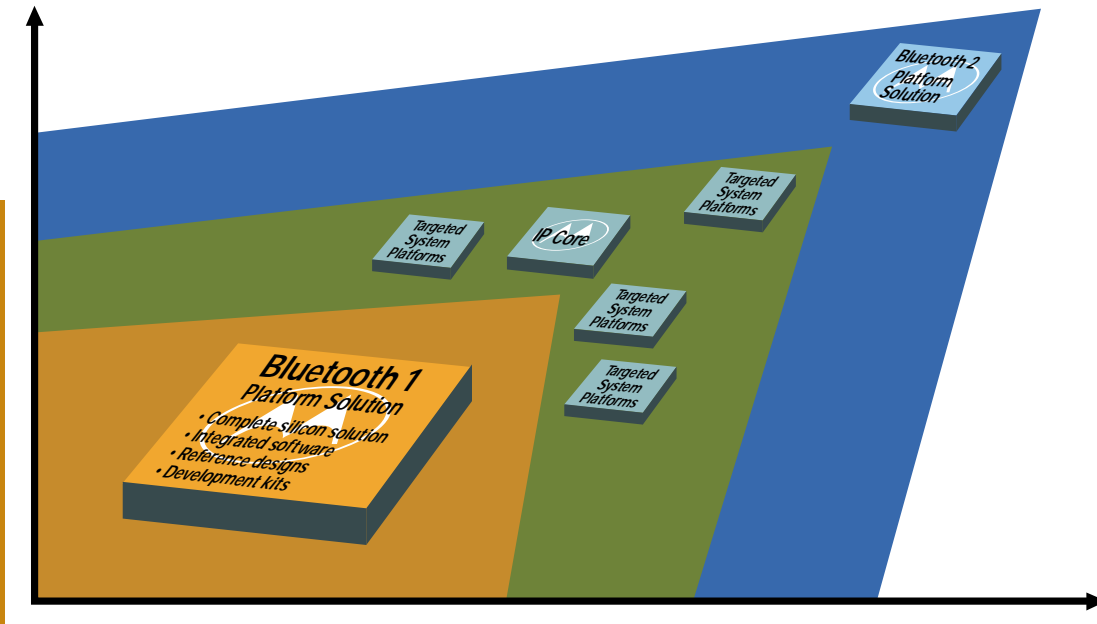

THE BLUETOOTH PLATFORM SOLUTION  
FROM MOTOROLA

*THE BLUETOOTH PLATFORM SOLUTION FROM MOTOROLA;  
A STRONG FOUNDATION FOR THE BLUETOOTH FUTURE*

We envision a future where all electronic devices are able to wirelessly network with each other. For Bluetooth to be a ubiquitous technology it must reach higher levels of performance, greater levels of integration and even better value than promised today. We are working with others to drive the high rate Bluetooth specification and adding improvements to the current standards.

Our personal area networking vision is about life in the connected world. Things that we normally do today, like standing in line and waiting by the phone, will become things of the past. It will no longer be just a dream to access our personal and business data from wherever we happen to be. We will be able to do it—easily, simply, instantly.



MOTOROLA and the Stylized M Logo are registered in the US Patent & Trademark Office. All other product or service names are the property of their respective owners. The Bluetooth trademarks are owned by their proprietor and used by Motorola, Inc. under license. ARM is a registered trademark of ARM Limited. © Motorola, Inc. 2001.

<http://www.motorola.com/semiconductors/bluetooth>